

改訂回数	日付	記事	担当
1	10/12/01	寸法削除	津久井
2	12/09/20	仕様変更	津久井

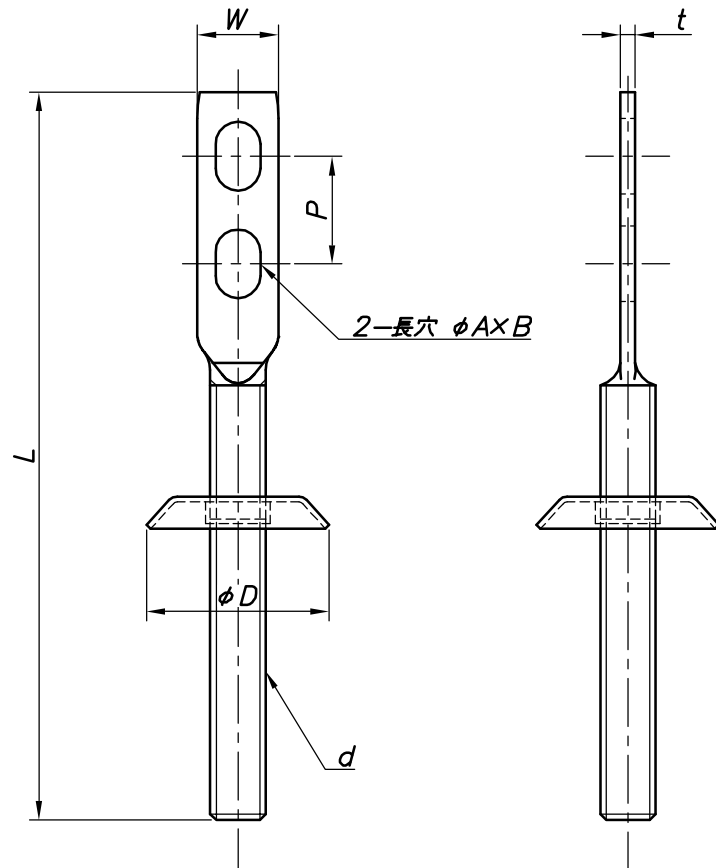

型番	規格 (ネジ長さ)	L	W	t	長穴	d	P	phi D
					phi A x B			
Z-HAT30	30	80	17	3.0	8.5 x 13	W3/8	20	38
Z-HAT50	50	100						
Z-HAT65	65	115						
Z-HAT75	75	125						
Z-HAT100	100	150						
Z-HAT125	125	175						
Z-HAT150	150	200						
Z-HAT200	200	250						
Z-HAT250	250	300						
Z-HAT300	300	350						
Z-HATW3*100-3	W3/8 x 100	160	18	3.0	11 x 18	W3/8	27	38
Z-HATW3*150-3	W3/8 x 150	210						
Z-HATW3*200-3	W3/8 x 200	260						
Z-HATW3*300-3	W3/8 x 300	360						
Z-HATW4*100-3	W1/2 x 100	160	20	4.5	11 x 18	W1/2	27	38
Z-HATW4*150-3	W1/2 x 150	210						
Z-HATW4*200-3	W1/2 x 200	260						
Z-HATW4*300-3	W1/2 x 300	360						

照合符号	ターボ用羽子板ボルト	鋼製	数量	溶融亜鉛メッキ
	名称	材料		摘要
日付	縮尺	形式		
10/04/01	NONE			
承認	審査	担当	図名 溶融亜鉛メッキ HAT ターボ用羽子板ボルト 標準図	
部門:			図番	
株式会社 昭利コーポレーション			STD-252-111	2